

- 50 to 750 mm. stroke
- Mechanical fixing and selfaligning linkage using 2 ball-joints
- Maximum angular movement up to $\pm 30^\circ$
- Independent linearity $\pm 0,05\%$
- Repeatability 0,01 mm.
- Infinite resolution
- No variation of electrical signal outside theoretical electrical stroke
- Displacement speed up to 5 m/s
- Working temperature: $-30\dots+100^\circ\text{C}$
- Electrical connections:
PC H 3-pole connector
PC M 4-pole connector to standard DIN43650-ISO4400
PC B 5-pole connector (DIN43322)
PC F 3-pole screened cable (1 m length)
- Life duration: $> 25 \times 10^6$ meters or $> 100 \times 10^6$ operations, whichever is the smaller (within C.E.U.)
- Grade of protection IP65
- Suitable for use in explosive environments with presence of gas (groups IIA, IIB, IIC) and combustible powders. Standards for simple device:
ATEX CEI EN 50020 2003 - paragraph 5.4 a

TECHNICAL DATA

Useful electrical stroke (C.E.U.)	50/100/130/150/175/200/225/275/ 300/360/375/400/450/500/600/750
Independent linearity (within C.E.U.)	$\pm 0,05\%$
Displacement speed	≤ 5 m/s
Displacement force	≤ 10 N
Vibrations	5...2000Hz, $A_{max} = 0,75$ mm $a_{max} = 20$ g
Shock	50 g, 11ms.
Tolerance on resistance	$\pm 20\%$
Recommended cursor current	$< 0,1 \mu\text{A}$
Maximum cursor current	10mA
Maximum applicable voltage	60V
Electrical isolation	$> 100\text{M}\Omega$ at 500V=, 1bar, 2s
Dielectri strength	$< 100 \mu\text{A}$ at 500V~, 50Hz, 2s, 1bar
Dissipation at 40°C (0W at 120°C)	3W
Actual Temperature Coefficient of the output voltage	$< 1,5\text{ppm}/^\circ\text{C}$
Working temperature	$-30\dots+100^\circ\text{C}$
Storage temperature	$-50\dots+120^\circ\text{C}$
Case material	Anodised aluminium Nylon 66 G25
Control rod material	Stainless steel AISI 303
Fixing	2 selfloading and selfaligning ball-joints

MECHANICAL DIMENSIONS

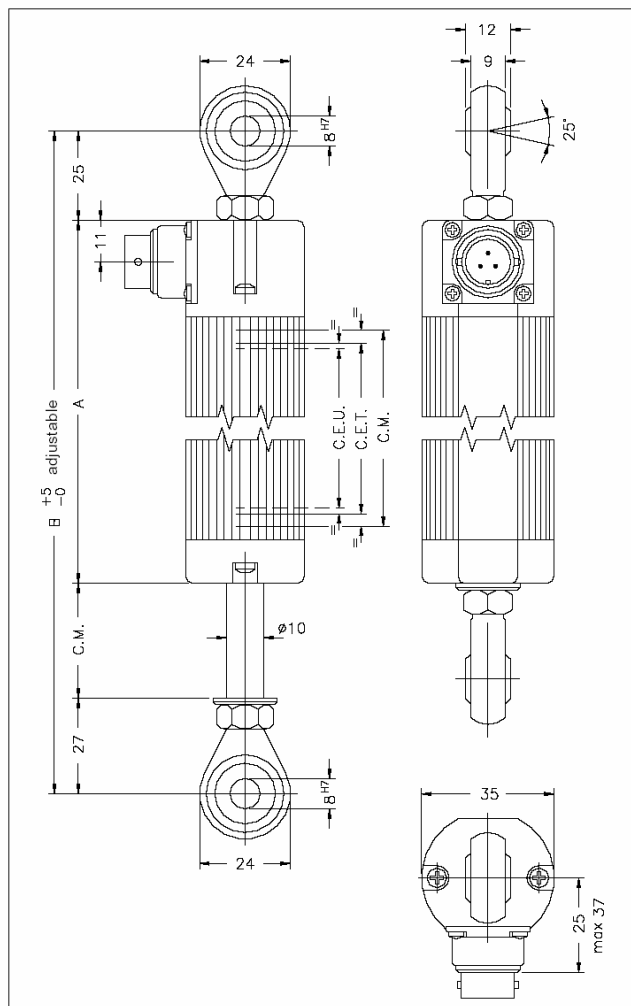

Important: all the data reported in the catalogue linearity, lifetime, temperature coefficient are valid for a sensor utilization as a ratiometric device with a max current across the cursor $I_c \leq 0.1 \mu\text{A}$.

MECHANICAL / ELECTRICAL DATA

MODEL		50	100	130	150	175	200	225	275	300	360	375	400	450	500	600	750	
Useful electrical stroke (C.E.U.) +3/-0	mm	50	100	130	150	175	200	225	275	300	360	375	400	450	500	600	750	
Theoretical electrical stroke (C.E.T.) ± 1	mm	C.E.U. + 3					C.E.U. + 4					364	380	406	457	508	609	762
Resistance (C.E.T.)	kΩ	5					5					5	5	5	5	5	5	10
Mechanical stroke (C.M.)	mm	C.E.U. + 9					C.E.U. + 10					370	386	412	463	518	619	772
Case length (A)	mm	C.E.U. + 129					C.E.U. + 130					496	512	538	589	664	765	918
Min. distance between ball-joints (B)	mm	C.E.U. + 181					C.E.U. + 182					547,5	564	590	641	716	817	970

ELECTRICAL CONNECTIONS

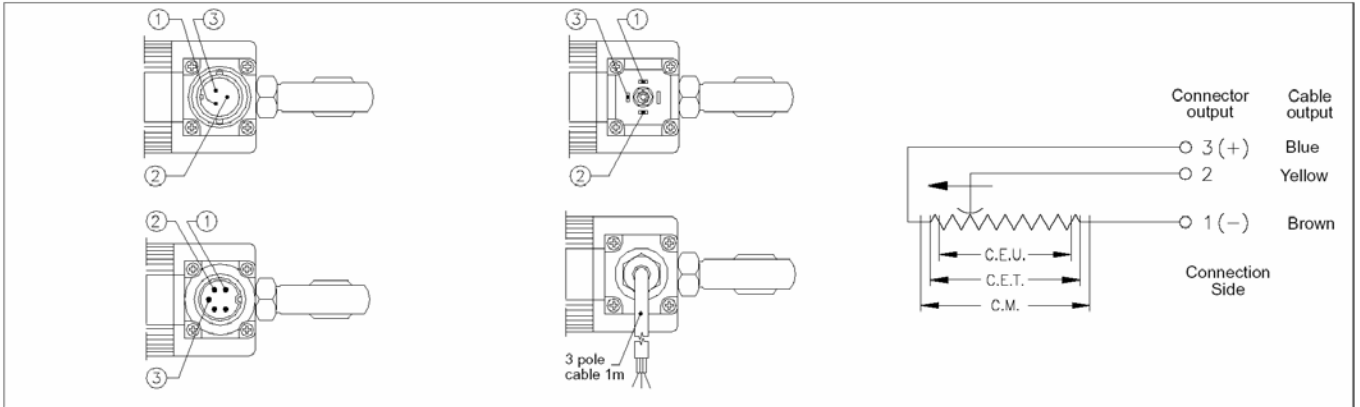

OPTIONAL ACCESSORIES

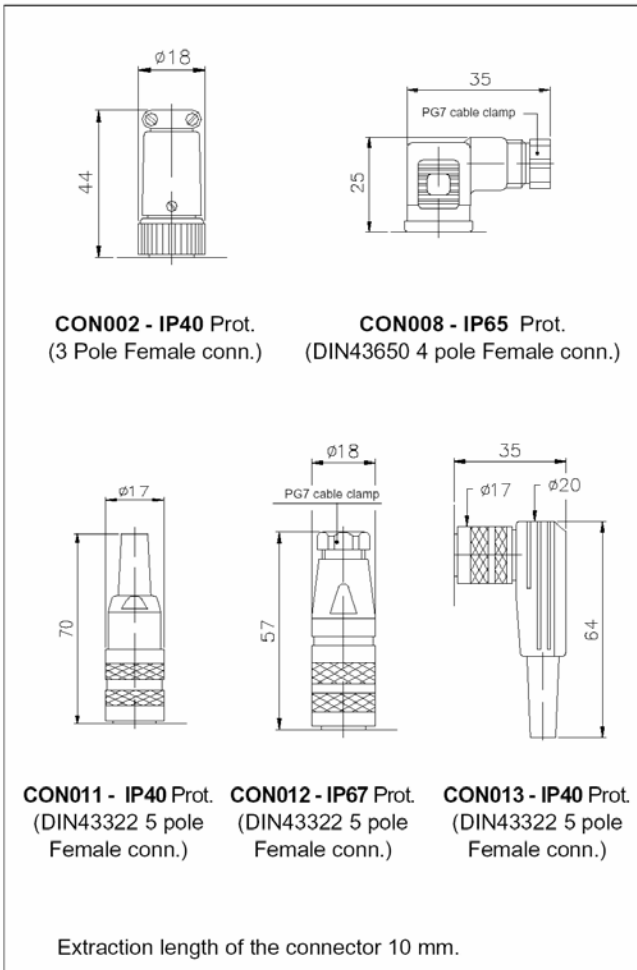

ORDER CODE

