

CSPM

HIGH CAPACITY COMPRESSION LOAD CELL



FEATURES

- Capacities: 10 - 100t
- Low profile, multi column stainless steel construction
- Hermetically sealed, IP66 and IP68
- Certified to OIML R-60, 4000d and NTEP class IIIIL 10000 divisions
- Built-in surge protection tubes (GDTs)
- Current calibration output (SC version) ensures easy and accurate parallel connection of multiple load cells

OPTIONAL FEATURES

- ATEX and FM certified versions are available for use in potentially explosive atmospheres
- Digital version available (model SCC)
- Multi-interval and multiple range versions available
- Imperial capacities (25K, 50K, 100K, 200Klbs) not OIML approved

DESCRIPTION

The CSP-M is a multi-column, low profile, stainless steel compression load cell. The unique four column design offers excellent insensitivity to eccentric loads whilst maintaining accuracy.

This product is, without doubt, one of the most successful compression cells ever produced and is suitable for use in road and rail

weighbridges and process weighing applications.

The fully leak-tested welded construction, advanced cable entry and built-in surge protection tubes ensure that this product can be used successfully in harsh environments.

This product meets the stringent Weights and Measures requirements throughout Europe.

APPLICATIONS

- Truck and rail weighbridges
- Silo and hopper weighing
- Process weighing

OUTLINE DIMENSIONS in millimeters

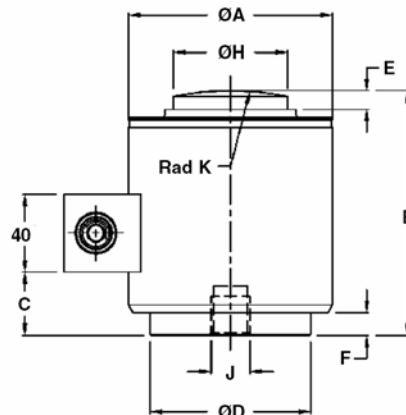
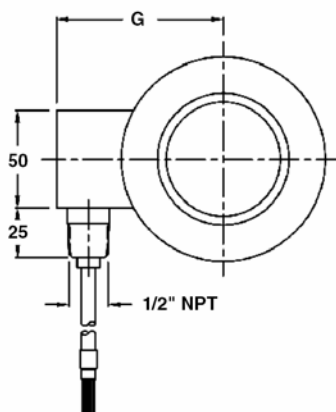

Cable specifications:

Cable length: 20m
(10m for 10t version)

Excitation + Green
Excitation - Black
Output + White
Output - Red
Shield Transparent

Cable screen is not connected to load cell body. Performance may be affected if load cell cables are shortened.

Capacity (t)	10, 25	40, 60	100
A	72.0	105.0	150.0
B	83.0	127.0	185.0
C	13.0	35.0	70.0
D	58.0	82.5	123.8
E	6.5	8.0	23.6
F	1.8	11.0	21.8
G	63.0	83.0	107.0
H	32.0	59.0	80.0
J	M12x1.75 (8 Deep)	M20x2.5 (15 Deep)	
K Rad	150.0	150.0	430.0

SPECIFICATIONS

PARAMETER	VALUE				UNIT
	NTEP IIIIL	Non-Approved	C3	C4	
Standard capacities (E_{max})	10, 25, 40, 60, 100				ton
Accuracy class according to OIML R-60 /NTEP					
Max. no. of verification intervals	10000		3000	4000	
Min. verification interval ($V_{min}=E_{max}/Y$)			$E_{max}/12,500$	$E_{max}/12,500$	
Min. verification interval, type MR			$E_{max}/17,500$	$E_{max}/17,500$	
Rated output (=S)	2				mV/V
Rated output tolerance	0.02				±mV/V
Zero balance	1.0				±% FSO
Combined error	0.0200	0.050	0.0200	0.0170	±% FSO
Non-repeatability	0.0100	0.020	0.0100	0.0090	±% FSO
Minimum dead load output return	0.0250	0.050	0.0167	0.0125	±% applied load
Creep error (30 minutes)		0.060	0.0245	0.0184	±% applied load
Creep error (20 - 30 minutes)	0.0300	0.0200	0.0053	0.0039	±% applied load
Temp. effect on min. dead load output	(0.0008)	0.0250	0.0056	0.0056	±% FSO/5°C (°F)
Temp. effect on min. dead load output, type MR			0.0040	0.0040	±% FSO/5°C
Temperature effect on sensitivity	(0.0010)	0.0250	0.0050	0.0035	±% applied load/5°C (°F)
Minimum dead load	0				% E_{max}
Maximum safe over load	150				% E_{max}
Ultimate over load	400				% E_{max}
Maximum safe side load	10				% E_{max}
Deflection at E_{max}	0.36 max.				mm
Excitation voltage	5 to 20				V
Maximum excitation voltage	25				V
Input resistance	450±4.5				Ω
Output resistance	480±4.8				Ω
Insulation resistance	≥5000				MΩ
Compensated temperature range	-10 to +40				°C
Operating temperature range	-40 to +80				°C
Storage temperature range	-50 to +90				°C
Element material	Stainless steel 1.4542				
Sealing (DIN 40.050 / EN60.529)	IP66 & IP68				

FSO-Full Scale Output

SC-version: The rated output and the output resistance are balanced in such a way, that the output current is calibrated to within 0.05% of a reference value. This allows easy parallel connection of the load cells.